

GreenGator 100

Intra-Flow Processing Technology™ (Patent Pending)

Introducing the Green Gator stand-alone, fully integrated, fully compatible and fully capable plastic processing and material re-purposing plants! There is no other technology in the world today that can process plastic waste the way our technology does... and that's a benefit to all of us, and the planet.

Our secret sauce is in the functionality of the machines and in how we get the machines to do what they do - process all plastics - and turn it into reusable products for you and me.

The GreenGator 100 is capable of processing over 500 pounds of plastic waste per hour and can consume for re-purposing over 2.5 million pounds of plastic waste per year! 2 employees are needed to operate this plant.

Basic Plant Configuration: A single compounding extruder with a single carousel for product tooling.

Major Features	Included	Optional
Categories of Plastic Materials (Categories 1 - 7)	Yes	
Large feed throat area (Improving Feed Speed Times)	Yes	
Variable Content Manager (Identification of Material Mixtures)	N/A	
Continuous Mix Feed (In-Process Mixture of Various Materials)	Yes	
Homogenization Process (Ensuring Clean Materials)	Yes	
Contaminated Material Processing (Most Contaminants)	Yes	
Direct Material Feed (Feed Shredded Materials)	Yes	
Processing Volume	500 lb./hour	
Compounding and Pumping Extruder	1	
Product Tool Carousel	1	
Product Tooling		20 station tooling



GREENABLE
TECHNOLOGY GROUP INC.

401 CAVENDISH DRIVE
WATERLOO, ON, CANADA N2T 2N6
T: 519.883.4171
GREENABLETECHNOLOGYGROUP.COM

GreenGator 100

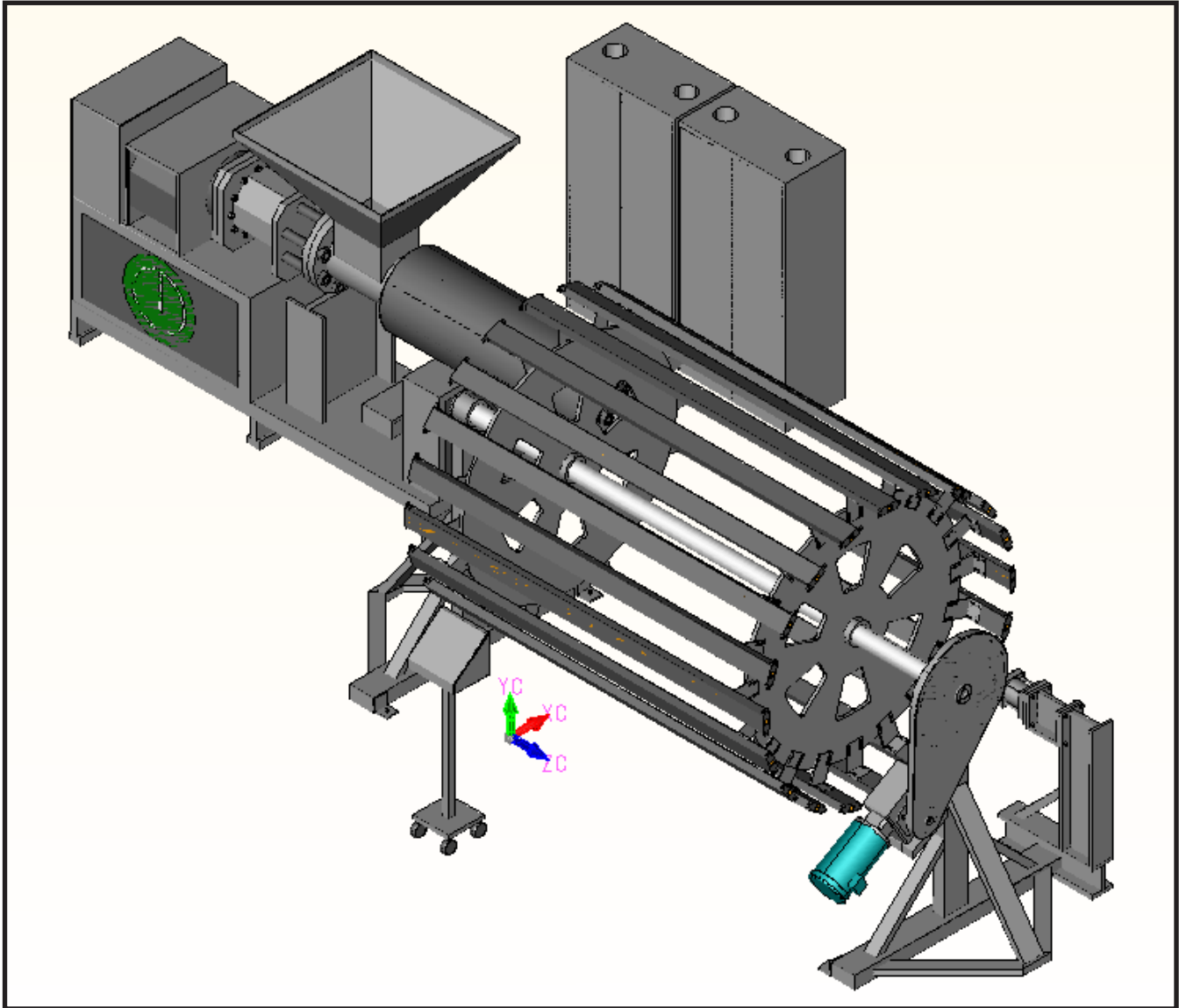

CREATING A **GREENER** TOMORROW.